

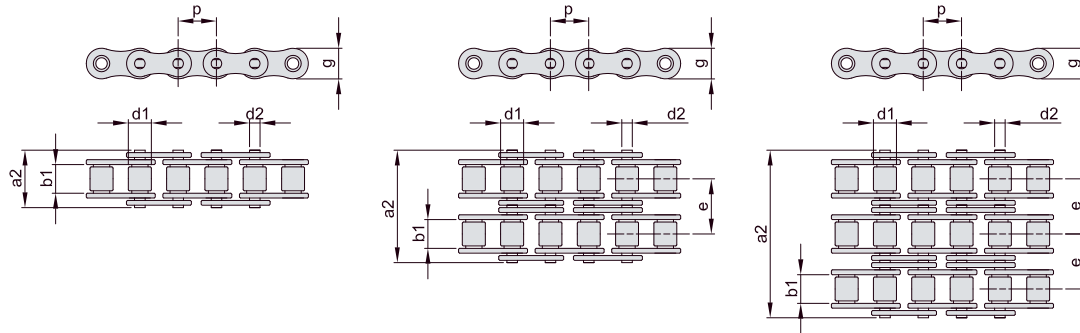

CATENE A RULLI SERIE AMERICANA - DIN 8188 - ANSI B29.1 "ASA" ROLLER CHAINS AMERICAN STANDARD - DIN 8188 - ANSI B29.1 "ASA"



CATENA PRODOTTA DA AZIENDA CERTIFICATA ISO 9001 - ISO 14001 E API 7F
CHAIN PRODUCED BY ISO 9001 - ISO 14001 AND API 7F CERTIFIED COMPANY

CATENA PRESTIRATA / PRE-STRETCHED CHAINS



SEMPLICE

| ANSI | p | | b ₁ mm min. | d ₂ mm | d ₁ mm max. | a ₂ mm max. | g mm max. | Carico di rottura | | q kg/m ≈ |
|--------|--------|-------|------------------------------|----------------------|------------------------------|------------------------------|-----------------|-------------------|-------------|----------------|
| | mm | inch | | | | | | minimo KN | medio KN | |
| 35-1 | 9,525 | 3/8" | 4,77 | 3,58 | 5,08 | 13,2 | 9,05 | 7,8 | 10,1 | 0,34 |
| 40-1 | 12,7 | 1/2" | 7,95 | 3,96 | 7,92 | 17,8 | 12,07 | 14,1 | 18,8 | 0,63 |
| 50-1 | 15,875 | 5/8" | 9,53 | 5,08 | 10,16 | 21,8 | 15,09 | 22,2 | 30,4 | 1,04 |
| 60-1 | 19,05 | 3/4" | 12,70 | 5,94 | 11,91 | 26,9 | 18,08 | 31,8 | 41,7 | 1,52 |
| 80-1 | 25,4 | 1" | 15,88 | 7,92 | 15,88 | 33,5 | 24,13 | 56,7 | 72,6 | 2,58 |
| 100-1 | 31,75 | 1"1/4 | 19,05 | 9,53 | 19,05 | 41,1 | 30,18 | 88,5 | 110,4 | 3,85 |
| 120-1 | 38,1 | 1"1/2 | 25,40 | 11,10 | 22,23 | 50,8 | 36,20 | 127,0 | 144,6 | 5,61 |
| 140-1 | 44,45 | 1"3/4 | 25,40 | 12,70 | 25,40 | 54,9 | 42,24 | 172,4 | 190,8 | 7,24 |
| 160-1 | 50,8 | 2" | 31,75 | 14,27 | 28,58 | 65,5 | 48,26 | 226,8 | 253,4 | 9,91 |
| 60-1H | 19,05 | 3/4" | 12,70 | 5,94 | 11,91 | 31,2 | 18,08 | 31,2 | 42,1 | 1,81 |
| 80-1H | 25,4 | 1" | 15,88 | 7,92 | 15,88 | 38,0 | 24,13 | 55,6 | 72,6 | 3,00 |
| 100-1H | 31,75 | 1"1/4 | 19,05 | 9,53 | 19,05 | 45,4 | 30,18 | 86,8 | 110,4 | 4,38 |

DOPPIA

| ANSI | p | | b ₁ mm min. | d ₂ mm | d ₁ mm max. | a ₂ mm max. | g mm max. | e mm | Carico di rottura | | q kg/m ≈ |
|-------|--------|-------|------------------------------|----------------------|------------------------------|------------------------------|-----------------|---------|-------------------|-------------|----------------|
| | mm | inch | | | | | | | minimo KN | medio KN | |
| 35-2 | 9,525 | 3/8" | 4,77 | 3,58 | 5,08 | 21,6 | 9,05 | 10,13 | 15,6 | 20,3 | 0,67 |
| 40-2 | 12,7 | 1/2" | 7,95 | 3,96 | 7,92 | 32,3 | 12,07 | 14,38 | 28,2 | 37,7 | 1,26 |
| 50-2 | 15,875 | 5/8" | 9,53 | 5,08 | 10,16 | 39,9 | 15,09 | 18,11 | 44,4 | 60,8 | 2,05 |
| 60-2 | 19,05 | 3/4" | 12,70 | 5,94 | 11,91 | 49,8 | 18,08 | 22,78 | 63,3 | 83,4 | 3,01 |
| 80-2 | 25,4 | 1" | 15,88 | 7,92 | 15,88 | 62,7 | 24,13 | 29,29 | 113,4 | 145,1 | 5,13 |
| 100-2 | 31,75 | 1"1/4 | 19,05 | 9,53 | 19,05 | 77,0 | 30,18 | 35,76 | 177,0 | 220,8 | 7,64 |
| 120-2 | 38,1 | 1"1/2 | 25,40 | 11,10 | 22,23 | 96,3 | 36,20 | 45,44 | 254,0 | 289,3 | 11,13 |
| 140-2 | 44,45 | 1"3/4 | 25,40 | 12,70 | 25,40 | 103,6 | 42,24 | 48,87 | 344,8 | 381,6 | 14,37 |
| 160-2 | 50,8 | 2" | 31,75 | 14,27 | 28,58 | 124,2 | 48,26 | 58,55 | 453,6 | 506,7 | 19,68 |

TRIPLA

| ANSI | p | | b ₁ mm min. | d ₂ mm | d ₁ mm max. | a ₂ mm max. | g mm max. | e mm | Carico di rottura | | q kg/m ≈ |
|-------|--------|-------|------------------------------|----------------------|------------------------------|------------------------------|-----------------|---------|-------------------|-------------|----------------|
| | mm | inch | | | | | | | minimo KN | medio KN | |
| 35-3 | 9,525 | 3/8" | 4,77 | 3,58 | 5,08 | 31,8 | 9,05 | 10,13 | 23,4 | 30,5 | 0,99 |
| 40-3 | 12,7 | 1/2" | 7,95 | 3,96 | 7,92 | 46,7 | 12,07 | 14,38 | 42,3 | 56,6 | 1,98 |
| 50-3 | 15,875 | 5/8" | 9,53 | 5,08 | 10,16 | 57,9 | 15,09 | 18,11 | 66,6 | 82,5 | 3,06 |
| 60-3 | 19,05 | 3/4" | 12,70 | 5,94 | 11,91 | 72,6 | 18,08 | 22,78 | 95,4 | 120,1 | 4,50 |
| 80-3 | 25,4 | 1" | 15,88 | 7,92 | 15,88 | 91,7 | 24,13 | 29,29 | 170,1 | 201,9 | 7,67 |
| 100-3 | 31,75 | 1"1/4 | 19,05 | 9,53 | 19,05 | 113,0 | 30,18 | 35,76 | 265,5 | 313,9 | 11,43 |
| 120-3 | 38,1 | 1"1/2 | 25,40 | 11,10 | 22,23 | 141,7 | 36,20 | 45,44 | 381,0 | 433,9 | 16,67 |
| 140-3 | 44,45 | 1"3/4 | 25,40 | 12,70 | 25,40 | 152,4 | 42,24 | 48,87 | 517,2 | 583,4 | 21,51 |
| 160-3 | 50,8 | 2" | 31,75 | 14,27 | 28,58 | 182,9 | 48,26 | 58,55 | 680,4 | 760,1 | 29,45 |