

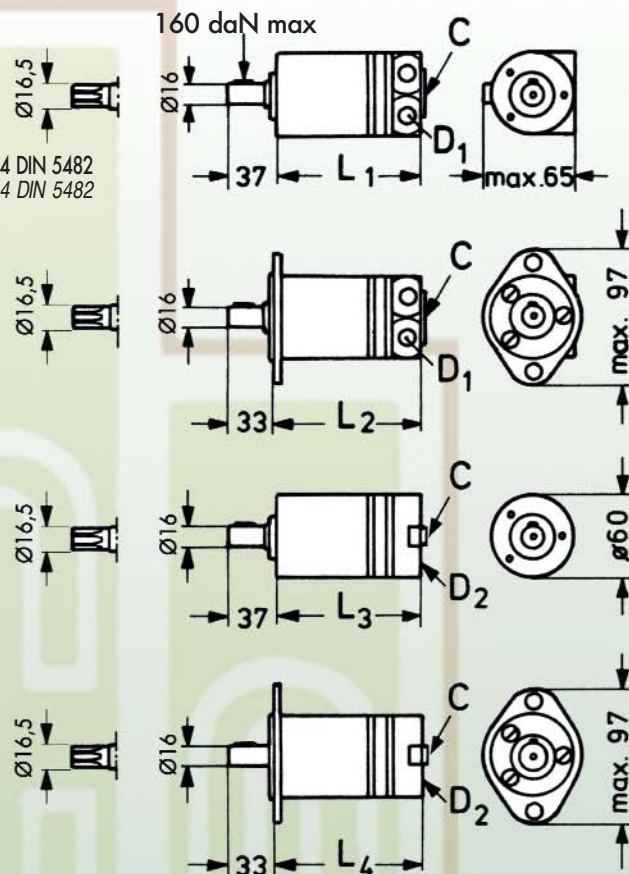

**Motore a distribuzione lineare
e albero a sostentamento
idrodinamico**

**Spool valve motor and
hydrodynamic slide bearing
supported shaft**

Albero scanalato B17 x 14 DIN 5482
Spined shaft B17 x 14 DIN 5482



C : connessioni di drenaggio: G1/8
drain ports: G1/8

D1: connessioni laterali: G3/8
side ports: G3/8

D2: connessioni posteriori: G3/8
back ports: G3/8

		OFM 8	OFM 12,5	OFM 20	OFM 32	OFM 50
Cilindrata / Displacement (cm ³)		8,2	12,9	20	31,8	50
Velocità max (RPM)	cont.	1950	1550	1000	630	400
Max speed (RPM)	int.	2440	1940	1250	790	500
Coppia max (daNm)	cont.	1,1	1,6	2,5	4	4,5
Max torque (daNm)	int.	1,5	2,3	3,5	5,7	8
Potenza max (kW)	cont.	1,8	2,4	2,4	2,4	1,7
Max output (kW)	int.	2,6	3,2	3,2	3,2	2,1
Caduta pressione max (bar)	cont.	130	130	130	130	100
Max pressure drop (bar)	int.	150	150	150	150	140
Portata max (l/min)	cont.	16	20	20	20	20
Max oil flow (l/min)	int.	20	25	25	25	25
L ₁ (mm)		109	111	114	119	122,5
L ₂ (mm)		112,5	114,5	117,5	122,5	126
L ₃ (mm)		104	106	109	114	121,5
L ₄ (mm)		107,5	109,5	115,5	117,5	125