

SERBATOI OLIO MULTIFISSAGGIO MULTIFITTINGS OIL TANKS

Tipo / Type **DIAMOND**

CAPACITÀ SERBATOIO L^t
TANK CAPACITY L^t

da/from 135
a/to 250



Serbatoio laterale
completo di kit
Side tank + kit
assembly



Serbatoio
retro-cabina
completo di kit
Rear cab tank + kit
assembly

* Serbatoio
Tank
(vedi tabella - see table)



Kit laterale/Side kit
13590300020
peso/weight 24 Kg
(150-170-200-250 lt)



Kit laterale/Side kit
13590300084
peso/weight 23,5 Kg
(solo/only 135 lt)



Kit retrocabina
Rear cab kit
13590302019
peso/weight 17 Kg

Sono serbatoi costruiti con le più moderne tecnologie per garantire la massima affidabilità e durata nel tempo, oltre che un aspetto esteriore perfettamente integrabile sui moderni trattori stradali. La gamma di accessori rende il loro impiego particolarmente flessibile. **La piastra cieca è fornita di serie.**

Based on the latest technology, these steel tanks are produced to ensure maximum reliability and longer lifetime as well as an exterior aspect that can be perfectly integrated. High versatility is granted by a wide choice of available accessories.

The blank flange is provided included in the standard equipment.

ACCIAIO VERNICIATO COATED STEEL (RAL 7021)		
Capacità nominale Filling capacity	* Codice serbatoio Tank code	Peso Weight Kg
135	135-910-11359	20
150	135-910-11500	22
170	135-910-11706	23.5
200	135-910-12009	25.5
250	135-910-02510	30

ALLUMINIO ALUMINIUM (G 2)		
Capacità nominale Filling capacity	* Codice serbatoio Tank code	Peso Weight Kg
135	135-913-11365	12
150	135-913-11516	13
170	135-913-11712	14
200	135-913-12015	15
250	135-913-02526	17

ALLUMINIO ALUMINIUM (G 1-1/2)		
Capacità nominale Filling capacity	* Codice serbatoio Tank code	Peso Weight Kg
135	135-913-11356	12
150	135-913-11507	13
170	135-913-11703	14
200	135-913-12006	15
250	135-913-02517	17



G2



G1-1/2



* Codice serbatoio senza kit. Il kit di montaggio deve essere ordinato separatamente scegliendo tra laterale e retro-cabina.
Part Number for oil tank only, without mounting kit. The mounting kit has to be ordered separately, choosing among the side or rear cab versions.

Il serbatoio completo di kit viene fornito imballato in 2 scatole singole (serbatoio e kit).
The complete tank consists of 2 single boxes (oil tank + mounting kit) packed together.

pag.21

INGOMBRO SERBATOI - TANKS DIMENSION

Livello olio / Oil level

725 / 710

640

90

A

Bocchettone ritorno. Tappo incluso. Return port. Plug included. G 1"1/4

Bocchettone aspirazione. Suction port. G 1"1/2 opp. G 2 (solo per alluminio/only for aluminium)

160

62

Bocchettone ritorno. Tappo incluso. Return port. Plug included. G 1"1/4

Bocchettoni aspirazione. Suction ports. G 1"1/2

140

160

210

256

115

Predisposizione filtro. Filter predisposition.

Capacità fino a livello olio / Capacity until oil level indicator	A mm
120	350 mm
140	400 mm
155	450 mm
175	500 mm
215	600 mm

Predisposizione filtro. Filter predisposition.

256

210

175

Predisposizione filtro. Filter predisposition.

Lt.135-150-170-200

Lt.250

INGOMBRO SERBATOIO CON KIT - TANK WITH KIT DIMENSIONS

Montaggio laterale / Side mounting

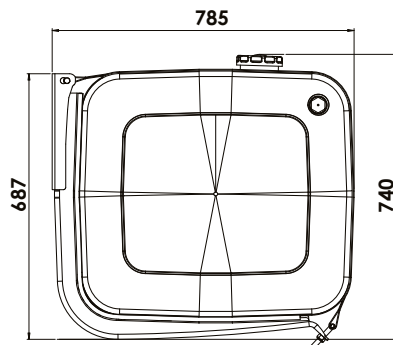

Montaggio retro-cabina / Rear cab mounting

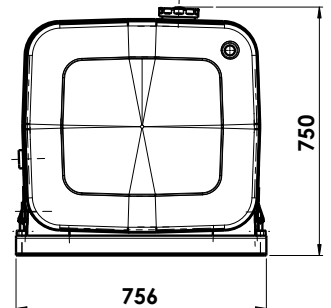

Ricambi / Spare parts	
	R1 135-990-30403 KIT 2 perni + 2 dadi fissaggio supporti serbatoio. Pins and nuts (2 of each) mounting kit for oil tank
	R2 135-990-30216 Fascia inox fissaggio serbatoio Stainless steel strap for oil tank
	R3 135-990-30305 Antivibrante in PVC protez.fascia inox PVC protection for oil tank strap
	R4 135-990-00712 Protezione in gomma. Rubber protection.
	538-000-00617 Staffa supporto STANDARD. Mounting brackets STANDARD. Kit 135-903-00020
	R5 538-000-00751 Staffa DX - Right bracket (135 lt) - Kit 135-903-00084
	538-000-00760 Staffa SX - Left bracket (135 lt) - Kit 135-903-00084
	R1 135-990-30314 Antivibrante in PVC protez. fascia inox. PVC protection for oil tank strap
	R2 135-990-30234 Fascia inox fissaggio serbatoio Stainless steel strap for oil tank
	R3 506-000-02845 Supporto antivibrante PVC protection
	R4 538-004-01907 Staffa supporto Mounting brackets
	R5 505-005-00148 Dado M12 M12 nut

118-013-00201 : TAPPO DI RIEMPIMENTO / FILLER CAP
 Compreso nel kit di montaggio. Solo per ricambi
 Included with the mounting kit. Only for spare part



509-004-00043: LIVELLO OLIO / OIL LEVEL
 Già compreso nel serbatoio. Solo per ricambi
 Already included with the tank. Only for spare part



Filtro e piastra di chiusura predisposta per il montaggio della valvola / Filter and mounting flange for tipping valve

	CAPACITÀ SERBATOIO / TANK CAPACITY	135 L 150 L 170 L 200 L		VALVOLA / VALVE	FM / FP 80 Modular 150 AL	PIASTRA PER VALVOLA VALVE MOUNTING PLATE	121-994-00182	
							Modular 150 AL Modular 250	121-994-00226
		250 L		VALVOLA / VALVE	Modular 150 AL Modular 250		121-994-00217	
		135 L 150 L 170 L 200 L			FILTRO / FILTER		118-001-12176	25 µm
				118-001-11177			60 µm	
				118-001-12756			30 µm	
		250 L		118-001-11757			60 µm	

Filtro flangiato senza possibilità di montare valvole / Filter without mounting flange for tipping valves

<p>Filtro flangiato Flangible filter (vedi tabella 2-3 see table 2-3)</p>	Serbatoio/Tank 135 L 150 L 170 L 200 L		Acciaio / Steel 90 µm	G 3/4	90 L	118-001-00358		
			Acciaio / Steel 90 µm	G 1	105 L	118-001-00401		
			Acciaio / Steel 60 µm	G 3/4	85 L	118-001-01357		
			Acciaio / Steel 60 µm	G 1	100 L	118-001-01400		
			Acciaio / Steel 60 µm	G 1	145 L	118-001-01437		
			Acciaio / Steel 60 µm	G 1	170 L	118-001-01446		
			Acciaio / Steel 60 µm	G 1 1/4	170 L	118-001-01455		
			Acciaio / Steel 60 µm	G 1	200 L	118-001-01482		
			Cellulosa rinforzata Reinforced cellulose 25 µm	G 3/4	75 L	118-001-02356		
			Cellulosa rinforzata Reinforced cellulose 25 µm	G 1	100 L	118-001-02409		
			Cellulosa rinforzata Reinforced cellulose 25 µm	G 1	160 L	118-001-02436		
			Cellulosa rinforzata Reinforced cellulose 25 µm	G 1	175 L	118-001-02445		
			Cellulosa rinforzata Reinforced cellulose 25 µm	G 1 1/4	175 L	118-001-02454		
			Microfibra Micro-fibre glass 25 µm	G 3/4	55 L	118-001-04354		
			Microfibra Micro-fibre glass 25 µm	G 1	75 L	118-001-04407		
			Cellulosa rinforzata Reinforced cellulose 10 µm	G 3/4	55 L	118-001-03355		
			Cellulosa rinforzata Reinforced cellulose 10 µm	G 1	75 L	118-001-03408		
			Serbatoio Tank 250 L		Acciaio / Steel 90 µm	G 1 1/4	270 L	118-001-00509
					Acciaio / Steel 60 µm	G 1 1/4	260 L	118-001-01508
					Cellulosa rinforzata Reinforced cellulose 25 µm	G 1 1/4	270 L	118-001-02507
Microfibra Micro-fibre glass 25 µm	G 1 1/4	220 L			118-001-04505			
Cellulosa rinforzata Reinforced cellulose 10 µm	G 1 1/4	220 L	118-001-03506					

Filtro flangiato orientabile senza possibilità di montare valvole / Adjustable filter without mounting flange for tipping valves

		Rete metallica Metallic net 60 µm	G 1 1/4	250 L	118-001-01571
		Microfibra Micro-fibre glass 25 µm	G 1 1/4	130 L	118-001-04904
		Cellulosa rinforzata Reinforced cellulose 10 µm	G 1 1/4	170 L	118-001-03677

Calotta senza cartuccia filtro - 1 ritorno G 1 / 135-904-00056
Cap without filter cartridge - 1 return port G1 / 135-904-00056

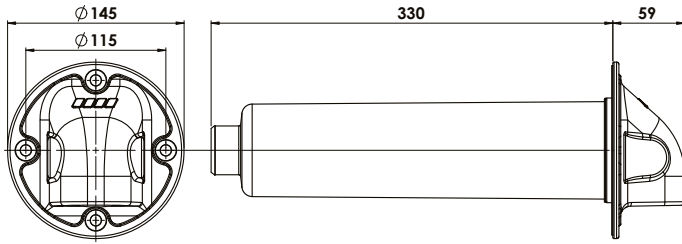

Calotta completa di cartuccia filtro 1 ritorno
Cap complete with filter cartridge 1 return port

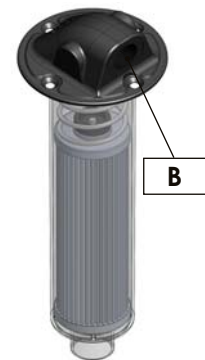
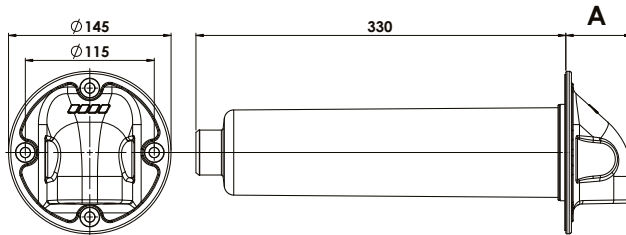

Cartuccia Cartridge	Codice Code	A	B
60 µm (acciaio/steel) 200 lt	118-001-20032	59	G 1
	118-001-20050	69	G 1-1/4
25 µm (cellulosa/cellulose) 160 lt	118-001-20041	59	G 1
	118-001-20069	69	G 1-1/4
25 µm (fibra/fiber) 160 lt	118-001-20078	59	G 1
	118-001-20087	69	G 1-1/4

Calotta completa di cartuccia filtro 1 ritorno e 2 ritorni ausiliari
Cap complete with filter cartridge 1 return and 2 auxiliary return ports

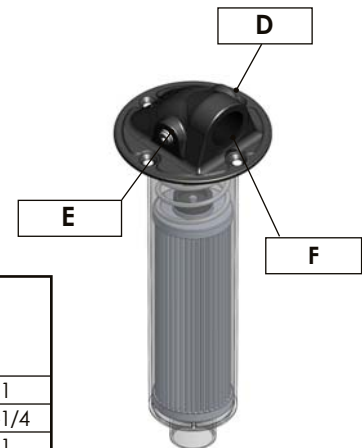
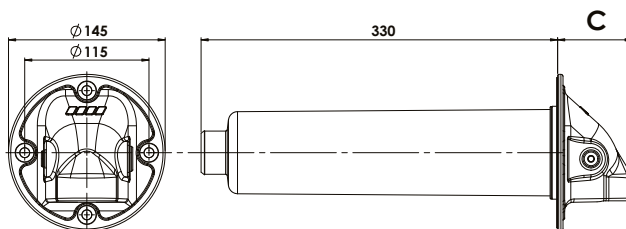

Cartuccia Cartridge	Codice Code	C	D	E	F
60 µm (acciaio/steel) 200 lt	118-001-20130	59	G 3/8	G 1/8	G 1
	118-001-20158	69	G 1/2	G 1/8	G 1-1/4
25 µm (cellulosa/cellulose) 160 lt	118-001-20149	59	G 3/8	G 1/8	G 1
	118-001-20167	69	G 1/2	G 1/8	G 1-1/4
	118-001-20194	69	G 1/2	G 1/2	G 1-1/4
25 µm (fibra/fiber) 160 lt	118-001-20176	59	G 3/8	G 1/8	G 1
	118-001-20185	69	G 1/2	G 1/8	G 1-1/4

Cartuccia di ricambio / Spare cartridge

118-002-11176 acciaio/steel (60 µm-200 lt)
 118-002-12175 cellulosa rinforzata/reinforced cellulose (25 µm-160 lt)
 118-002-12194 cartuccia microfibra/ microfiber cartridge (25 µm-160 lt)